

CONTAINER TROLLIES SERIES F CP

The Series F CP Trolleys has been developed to optimize both the transportation and handling of materials. The design characteristic allows for both the adjustment of vertical height and the angled inclination of the shelves. The trolleys can be used for the transportation of materials with the shelves horizontal and be used close to a work station with inclined shelves to ease picking of the container contents. The trolleys are made from galvanized steel and fitted with conductive castors which offer full ESD protection control. This series of trolleys are suitable for both 400x300 mm and 600x400 mm. Euro-stacking containers and for the picking bins F PM 5752 00 07, F PM 6552 00 07 and F PM 7352 00 07.



Load capacity 180 kg
Shelf load capacity 100 kg

Art. F CP 1101 51 99
(without container)

Galvanized container trolley with three tilting shelves and conductive wheels.
Dimensions: mm 698x498x1286h
Shelf adjustment with pitch mm 25

Additional shelf galvanized
Art. F CP 1110 00 99
Dimensions: mm 630x410x27h

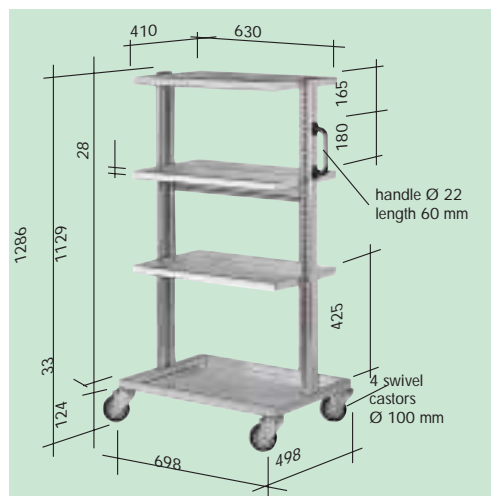

Load capacity 180 kg
Shelf load capacity 100 kg



Art. F CP 1201 51 99
(without container)

Galvanized container trolley with three tilting shelves and conductive wheels.
Dimensions: mm 1010x498x1286h
Shelf adjustment with pitch mm 25

Additional shelf galvanized
Art. F CP 1210 00 99
Dimensions: mm 940x410x27h